

■ CONSTRUCTION OF MAIN COMPONENTS

1. MG1 and MG2

General

- Serving as the source of supplemental motive force that provides power assistance to the engine as needed, the electric motor helps the vehicle achieve excellent dynamic performance, including smooth start-offs and acceleration. When the regenerative brake is activated, MG2 (Motor Generator No.2) converts the vehicle's kinetic energy into electrical energy, which is then stored in the HV battery.
- MG1 (Motor Generator No.1) recharges the HV battery and supplies electrical power to drive MG2. In addition, by regulating the amount of electrical power generated (thus varying the generator's rpm), MG1 effectively controls the continuously variable transmission function of the transaxle. MG1 also serves as the starter to start the engine.
- Both the MG1 and MG2 are compact, lightweight, and highly efficient alternating current permanent magnet synchronous type.
- Both the MG1 and MG2 use a rotor containing a V-shaped, high-magnetic force permanent magnet that maximizes the generation of reduction torque. They use a stator made of a low core-loss electromagnetic steel sheet and a high voltage resistant winding wire. Through these measures, the MG1 and MG2 have realized high output and torque in a compact construction.
- A cooling system via water pump for the MG1 and MG2 has been added. For details, refer to the cooling system (for Inverter, MG1 and MG2) on [page TH-27](#).

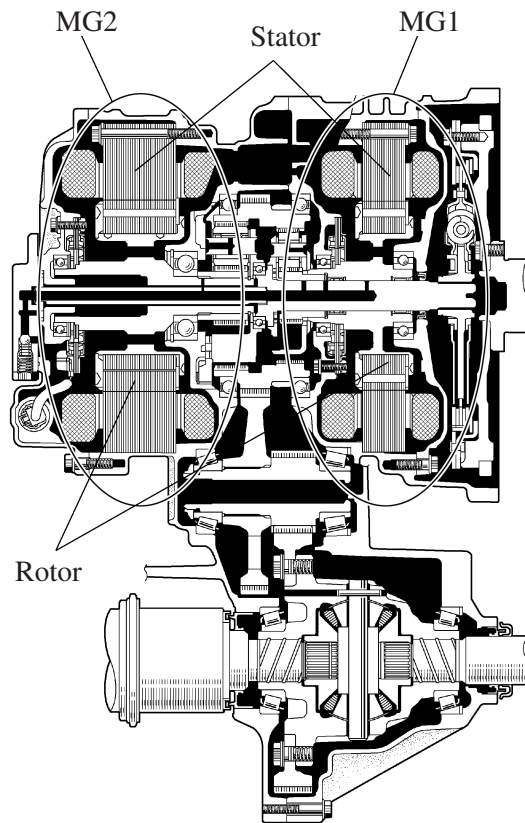

02HCH31Y

Hybrid Transaxle

► MG1 Specifications ◀

Type	Permanent Magnet Motor
Function	Generate, Engine Starter
Maximum System Voltage*	DC 650 V
Cooling System	Water-cooled

► MG2 Specifications ◀

Type	Permanent Magnet Motor
Function	Generate, Drive Front Wheels
Maximum System Voltage*	DC 650 V
Maximum Output	105 kW (141 HP)
Maximum Torque	270 N·m (199 ft·lbf)
Cooling System	Water-cooled

*: These voltage are converted into an alternating current and then supplied to MG1 and MG2.

► System Diagram ◀

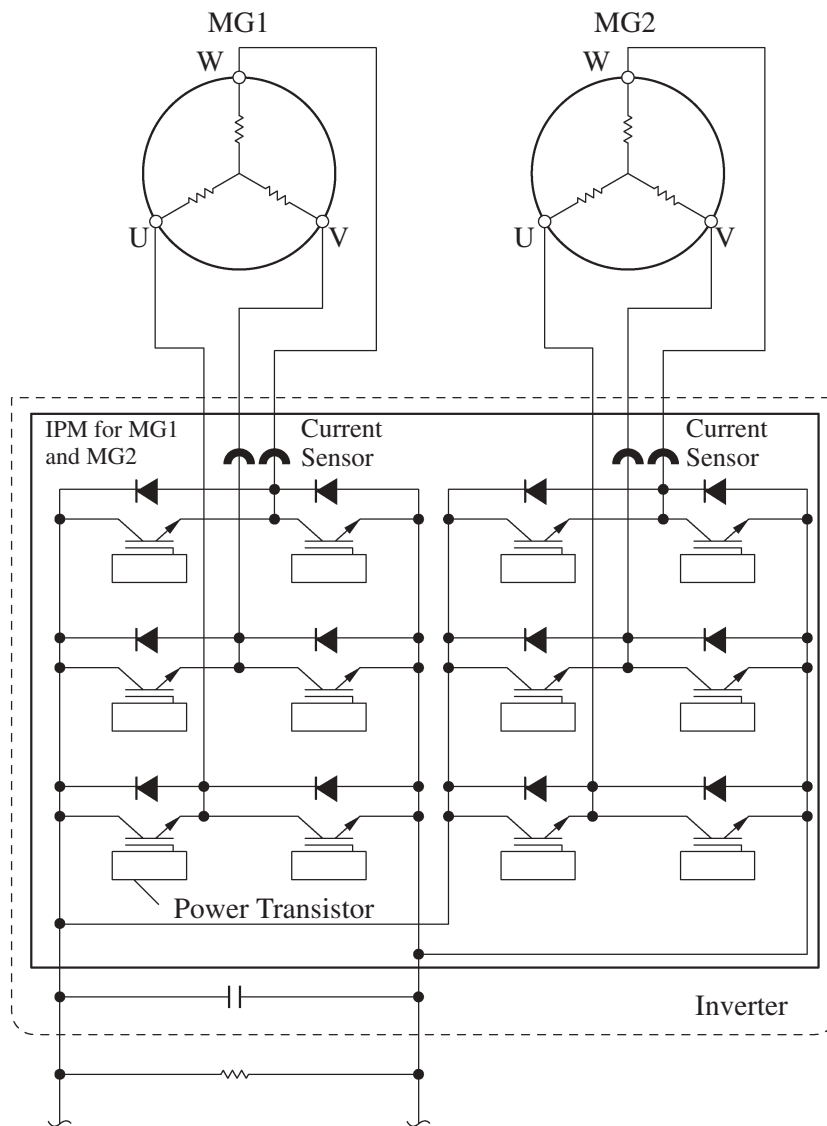

Permanent Magnet Motor (for MG1 and MG2)

- When a three-phase alternating current is passed through the three-phase windings of the stator coil, a rotational magnetic field is created in the electric motor. By controlling this rotating magnetic field according to the rotor's rotational position and speed, the permanent magnets that are provided in the rotor become attracted by the rotating magnetic field, thus generating torque. The generated torque is for all practical purposes proportionate to the amount of current, and the rotational speed is controlled by the frequency of the alternating current. Furthermore, a high level of torque, all the way to high speeds, can be generated efficiently by properly controlling the rotating magnetic field and the angles of the rotor magnets.
- When the motor generates electricity, the rotor rotates to create a magnetic field, which creates a current in the stator coil.

TH

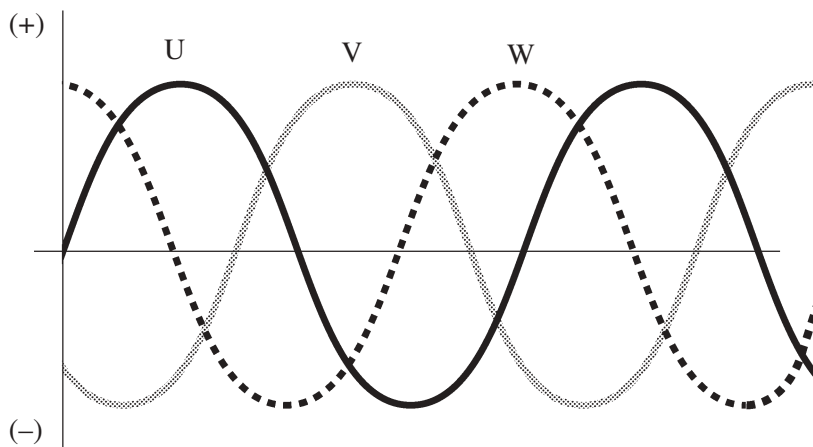
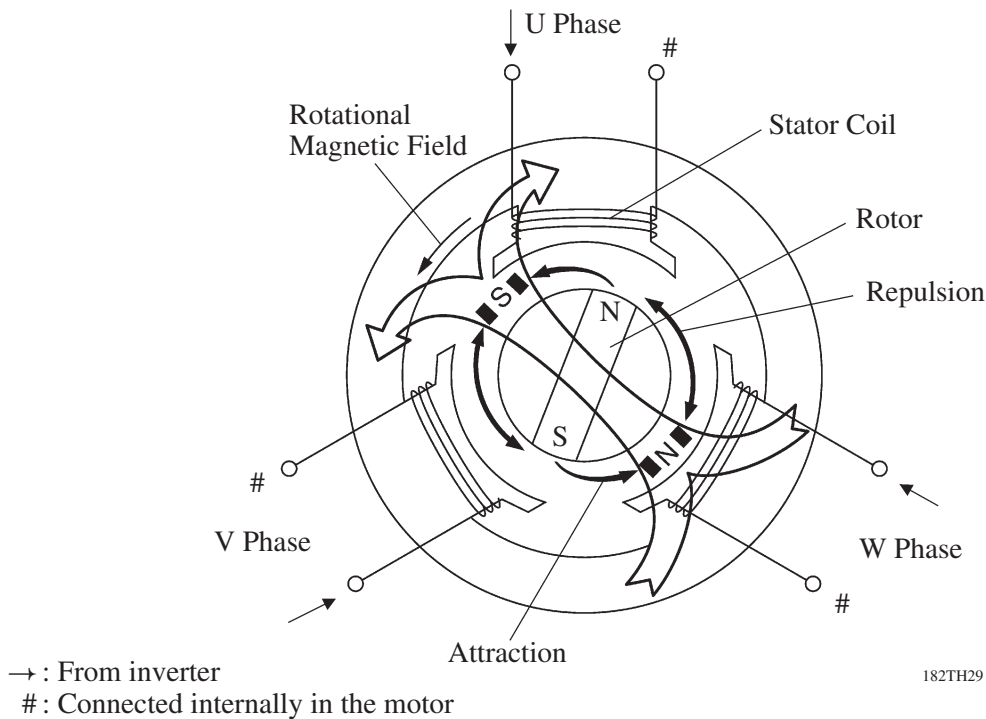

Three-phase Alternating Current Output Waveforms

Speed Sensor/Resolver (for MG1 and MG2)

- This is an extremely reliable and compact sensor that precisely detects the magnetic pole position, which is indispensable for ensuring the efficient control of MG1 and MG2.
- The stator of the sensor contains three types of coils: excitation coil A, detection coil S, and detection coil C. The detection coils S and C are electrically staggered 90 degrees. The rotor is oval, the distance of the gap between the stator and the rotor varies with the rotation of the rotor.
- The flow of an alternating current into an excitation coil A results in the output of signals of a constant frequency. Coil S and coil C output values that correspond to the position of the rotor. Therefore, the MG ECU detects the absolute position based on the difference between the coil S and coil C output values. Furthermore, the MG ECU calculates the rotational speed based on the amount of change in the position within a given length of time.

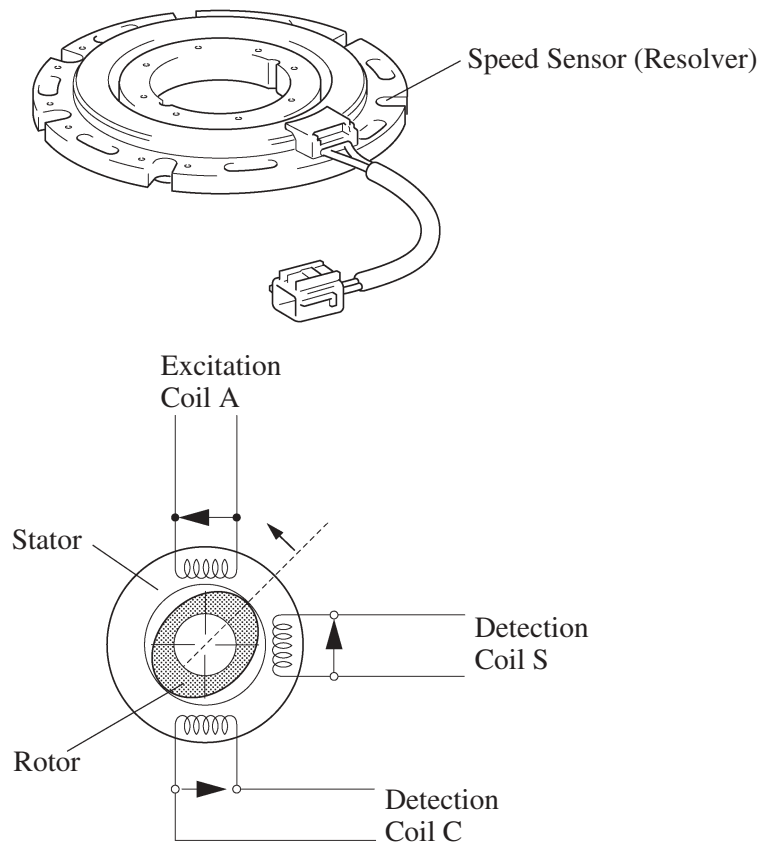

- Because an alternating current flows from this resolver to the excitation coil at a constant frequency, a constant frequency is output to the coils S and C, regardless of the rotor speed. The rotor is oval, and the distance of the gap between the stator and the rotor varies with the rotation of the rotor. Consequently, the peak values of the waveforms output by the coils S and C vary in accordance with the position of the rotor.
- The MG ECU constantly monitors these peak values, and connects them to form a virtual waveform. The MG ECU calculates the absolute position of the rotor from the difference between the values of the coils S and C. It determines the rotor direction based on the difference between the phases of the virtual waveform of the coil S and the virtual waveform of the coil C. Furthermore, the MG ECU calculates the rotational speed based on the amount of change in the rotor position within a given length of time.
- The diagrams below illustrate the waveforms that are output at coils A, S, and C when the rotor makes a positive rotation of 180° from a certain position.

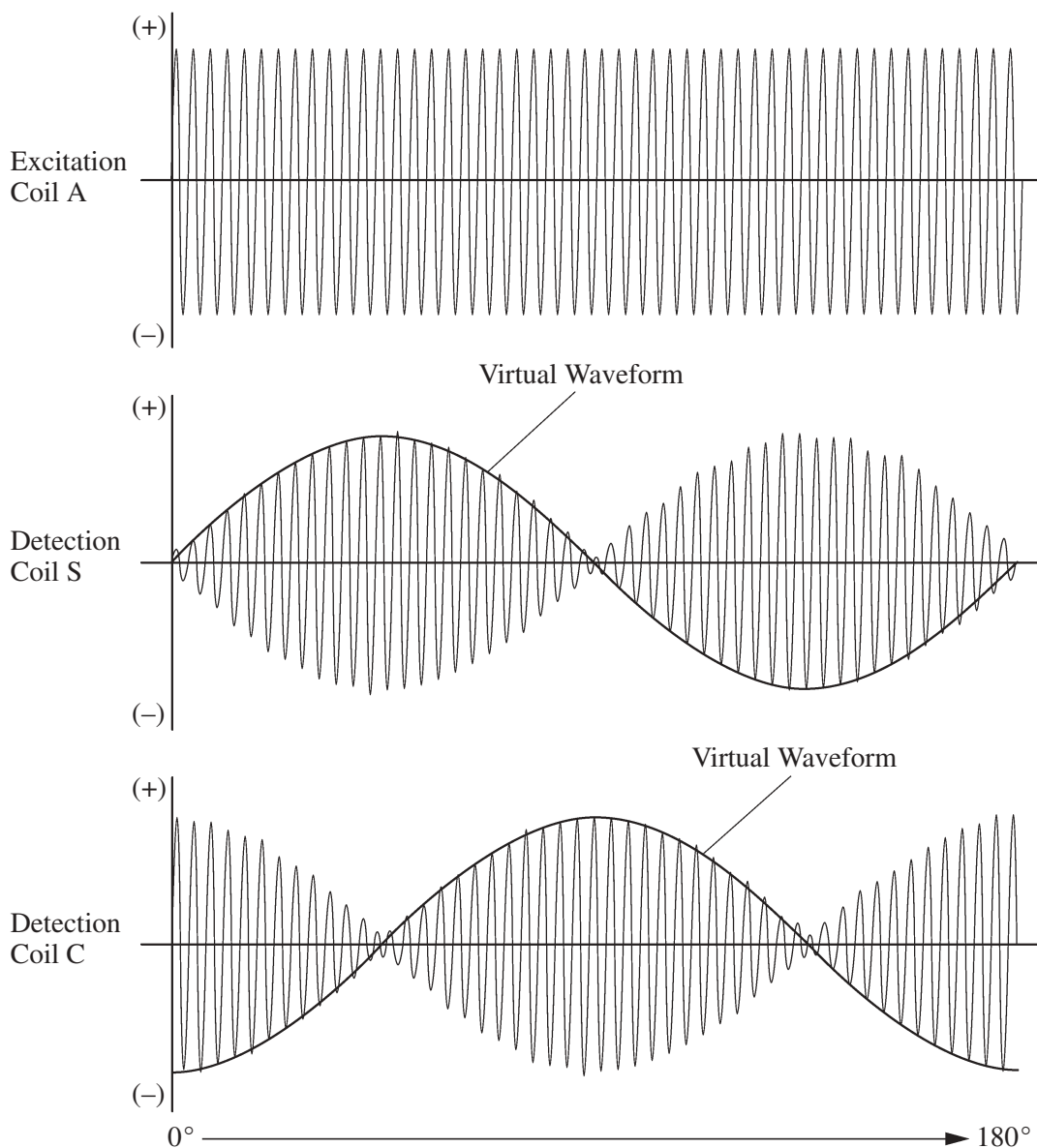

2. Inverter Assembly

General

- The inverter converts the high-voltage direct current of the HV battery into three-phase alternating current for driving MG1 and MG2.
- The activation of the power transistors is controlled by the THS ECU, via the MG ECU. In addition, the inverter transmits information that is needed for current control, such as the output amperage or voltage, to the THS ECU via the MG ECU.
- Together with MG1 and MG2, the inverter is cooled by the dedicated radiator of the coolant system that is separate from that of the engine.
- In the event of a collision involving the vehicle, the circuit breaker sensor, which is installed on the inverter, detects a collision signal in order to stop the system. For details, refer to During Collision Control on [page TH-54](#).
- A boost converter is used in the inverter assembly, in order to boost the nominal voltage output by the HV battery from DC 244.8 V to maximum voltage of DC 650 V. After the voltage is boosted, the inverter converts the direct current into an alternating current.
- Each of the bridge circuits for MG1 and MG2 contains 6 power transistors. In addition, a signal processor/protective function processor has been integrated into a compact IPM (Intelligent Power Module) for driving the vehicle.

For details on the multiple functions of the inverter, refer to Inverter Assembly Control on [page TH-49](#).

Inverter Assembly
(Included Inverter,
Boost Convert
and MG ECU)

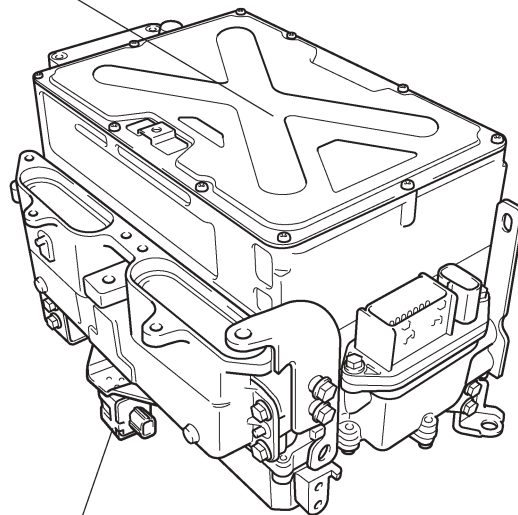

Circuit Breaker
Sensor (for Front)

02HTH23Y

► System Diagram ◀

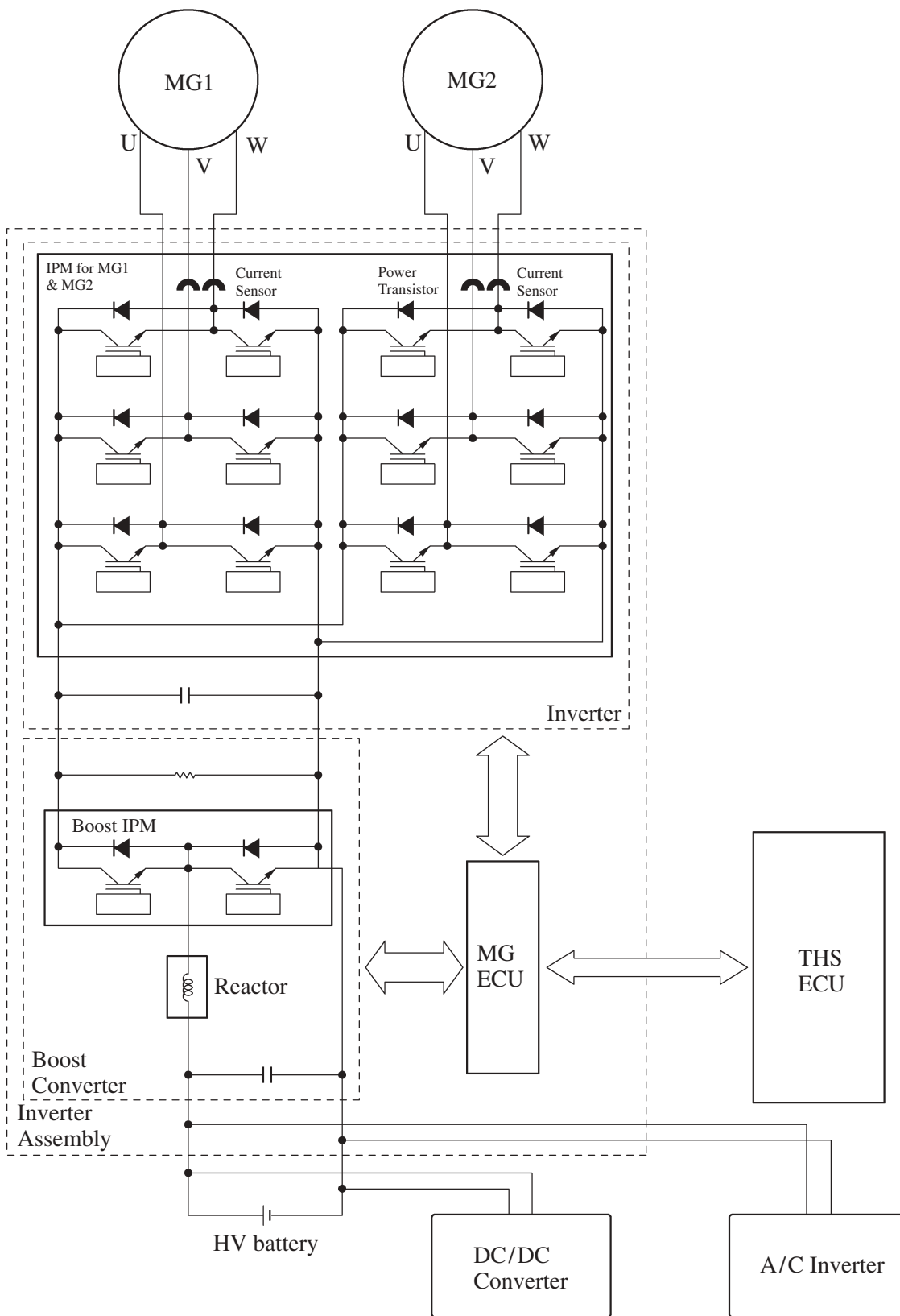

TH

Boost Converter

- This boost converter boosts the nominal voltage of DC 244.8 V that is output by the HV battery to the maximum voltage of DC 650 V. The converter consists of the boost IPM (Intelligent Power Module) with a built-in IGBT (Insulated Gate Bipolar Transistor) which performs the switching control, and the reactor which stores energy. By using these components, the converter boosts the voltage. For details, refer to Inverter Assembly Control on [page TH-49](#).
- When MG1 and MG2 acts as the generator, the inverter converts the alternating current into the maximum voltage of DC 650 V, and then the boost converter reduces the voltage to the nominal voltage of DC 244.8 V, thus the HV battery is charged.

► System Diagram ◀

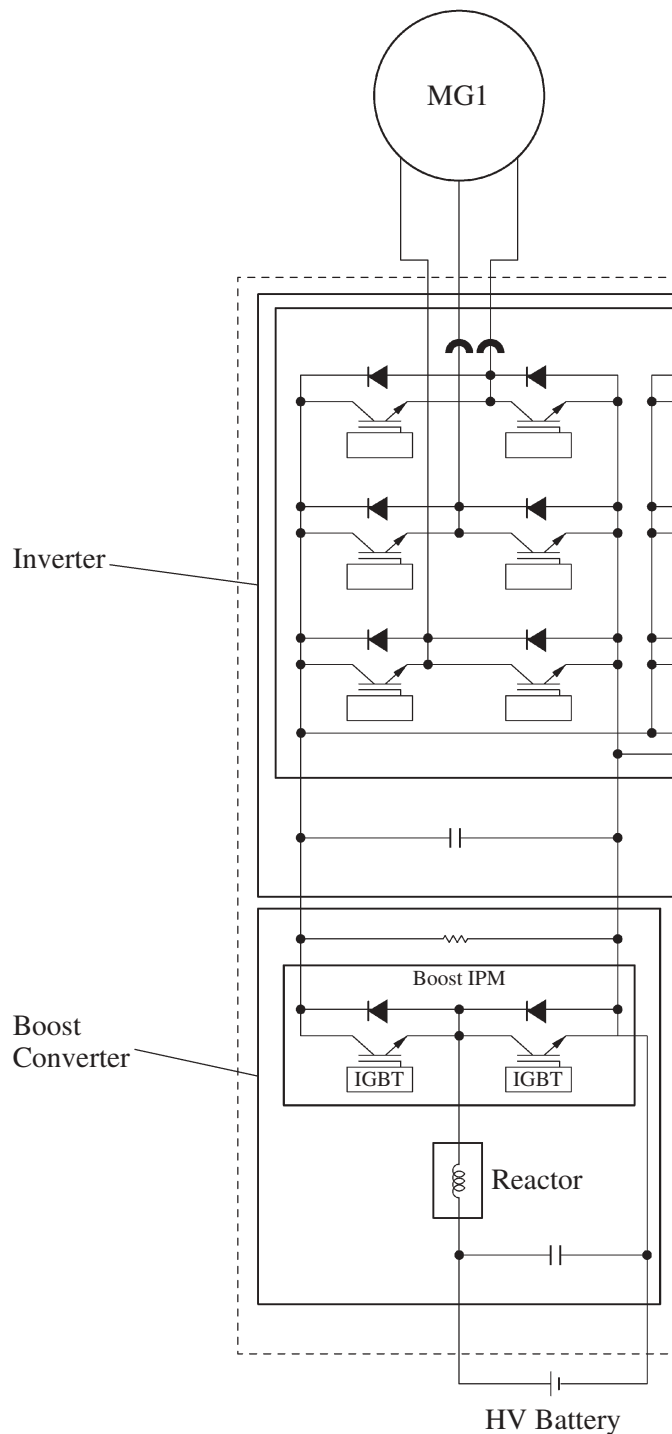

MG (Motor Generator) ECU

- The MG ECU is provided in the inverter assembly. In accordance with the signals received from the THS ECU, the MG ECU controls the inverter and boost converter in order to drive MG1 or MG2 or cause them to generate electricity.
- The MG ECU transmits information that is required for vehicle control, such as the inverter output amperage, inverter temperature, and any failure information, to the THS ECU. It receives information that is required for controlling the motor generator, such as the required motive force and the motor temperature, from the THS ECU.

3. Cooling System (for Inverter, MG1 and MG2)

- A cooling system that is independent from the engine cooling system has been provided to cool the inverter, MG1 and MG2.
- This cooling system activates when the power supply status is switched to the READY ON state.
- A radiator, which is exclusively used for the inverter, MG1 and MG2, has been provided above the condenser (for the A/C). By integrating the independent inverter radiator, A/C condenser and engine radiator, the layout has been made more compact.

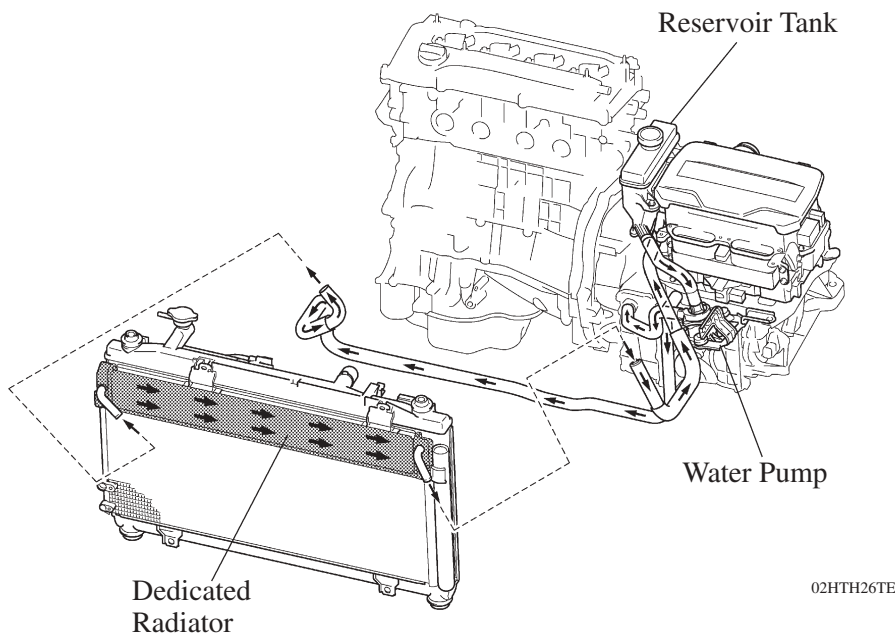

► Specifications ◀

Water Pump	Discharge Volume	liter/min.	10 or above (65°C (149°F))
Coolant	Capacity	liters (US qts, Imp. qts)	2.9 (3.1, 2.6)
	Type	TOYOTA Genuine Super Long Life Coolant (SLLC) or the equivalent*	
	Color	Pink	
	Maintenance Intervals	First Time	100,000 miles (160,000 km)
		Subsequent	Every 50,000 miles (80,000 km)

*: Similar high quality ethylene glycol based non-silicate, non-amine, non-nitrite, and non-borate coolant with long-life hybrid organic acid technology. (Coolant with hybrid organic acid technology consists of a combination of low phosphates and organic acids.)

- SLLC is pre-mixed (50% coolant and 50% deionized water for U.S.A. or 55% coolant and 45% deionized water for Canada), so no dilution is needed when adding or replacing SLLC in the vehicle.

4. HV Battery

General

- The '07 Camry Hybrid model uses sealed nickel metal hydride (Ni-MH) HV batteries. The HV batteries have a high power density, are lightweight and offer longevity to match the characteristics of the THS II. Because the THS II effects charge/discharge control to maintain the HV batteries at a constant SOC (state of charge) level while the vehicle is operating normally, it does not need to be recharged externally.
 - The HV batteries use nickel-plated, metal container type cells to realize enhanced cooling performance and a compact construction. As a result, high power density, lightweight construction, and longevity have been accomplished at high levels.
 - The HV battery unit consists of 34 separate batteries. The batteries each comprise 6 cells and they are connected to each other in series through a bus bar module. The cells of the batteries are connected at two locations in order to reduce the internal resistance and improve efficiency. The HV battery unit, which has a total of 204 cells (6 cells x 34 batteries) and a nominal voltage of 244.8 V (1.2 V x 204 cells), is located in the luggage compartment behind the rear seat.
 - A junction block, battery smart unit and DC/DC converter are used. Integrated into the junction block are an SMRG (System Main Relay Ground), SMRB (System Main Relay Battery) and a current sensor. The battery smart unit monitors the HV battery. The DC/DC converter supplies power to the auxiliary battery after decreasing the nominal voltage of DC 244.8 V supplied by the HV battery to DC 12 V. Power to the lights, audio system, air conditioning system (except the electric inverter compressor) and ECUs is supplied by the auxiliary battery.
- The battery smart unit, junction block, and DC/DC converter are located in the battery front side carrier, which is in the same housing as the HV battery unit. This realizes a compact package.
- An air-cooling method, which uses a dedicated cooling fan to cool the HV battery with air from inside the cabin, is employed. A dedicated cooling fan is also provided for the DC/DC converter. Thus, highly efficient air-cooling has been achieved.
 - A service plug that shuts off the circuit is provided in the middle of the HV battery modules (between No.18 and No.19 batteries). Before servicing any portion of the high-voltage circuit, be sure to remove the service plug.

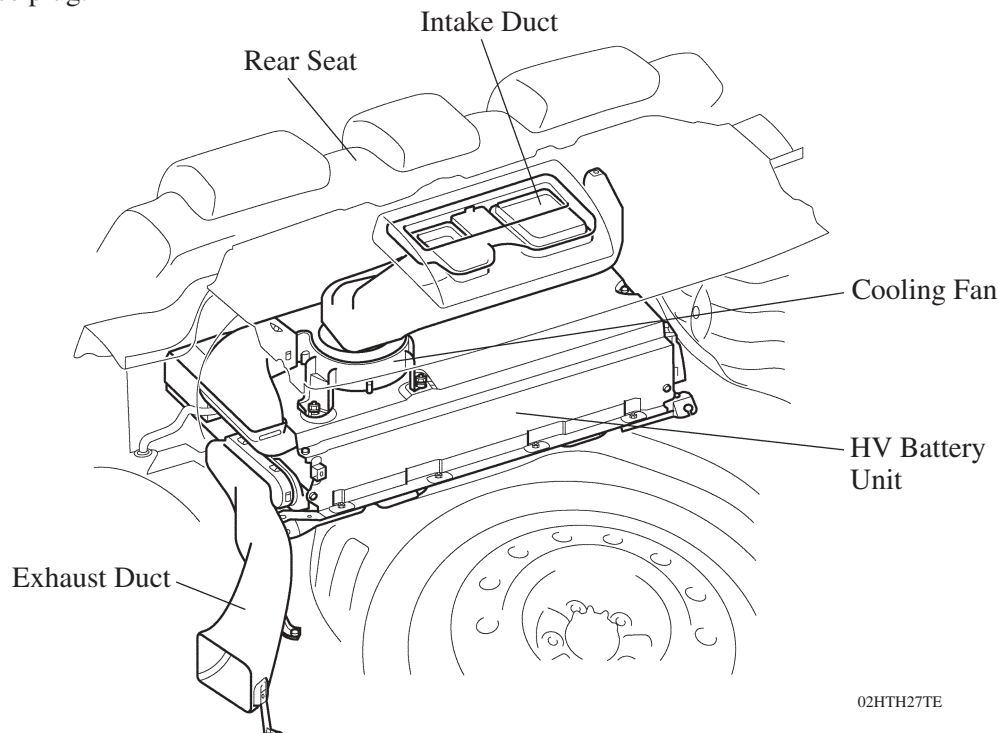

► Battery Specifications ◀

Type	Sealed Nickel Metal Hydride Battery
Cell Quantity	204 cells (6 cells x 34 Modules)
Cell Type	Nickel Plated Metal Container
Nominal Voltage	244.8 V

Layout of Main Components

TH

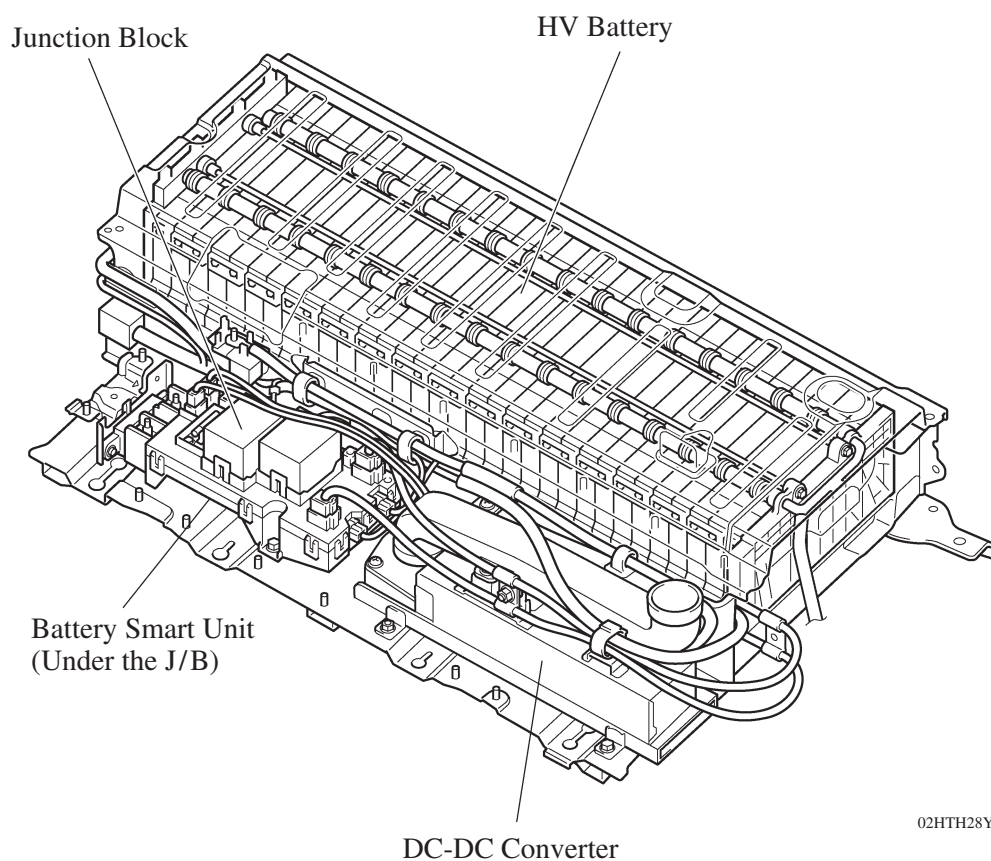

02HTH28Y

DC/DC Converter

The power source for auxiliary equipment of the vehicle such as the lights, audio system, and the air conditioning system (except electric inverter compressor), as well as the ECUs, is based on a DC 12 V system. Because the THS II generator outputs at nominal voltage of DC 244.8 V, the converter is used to transform the voltage from DC 244.8 V to DC 12 V in order to recharge the auxiliary battery.

► **System Diagram** ◀

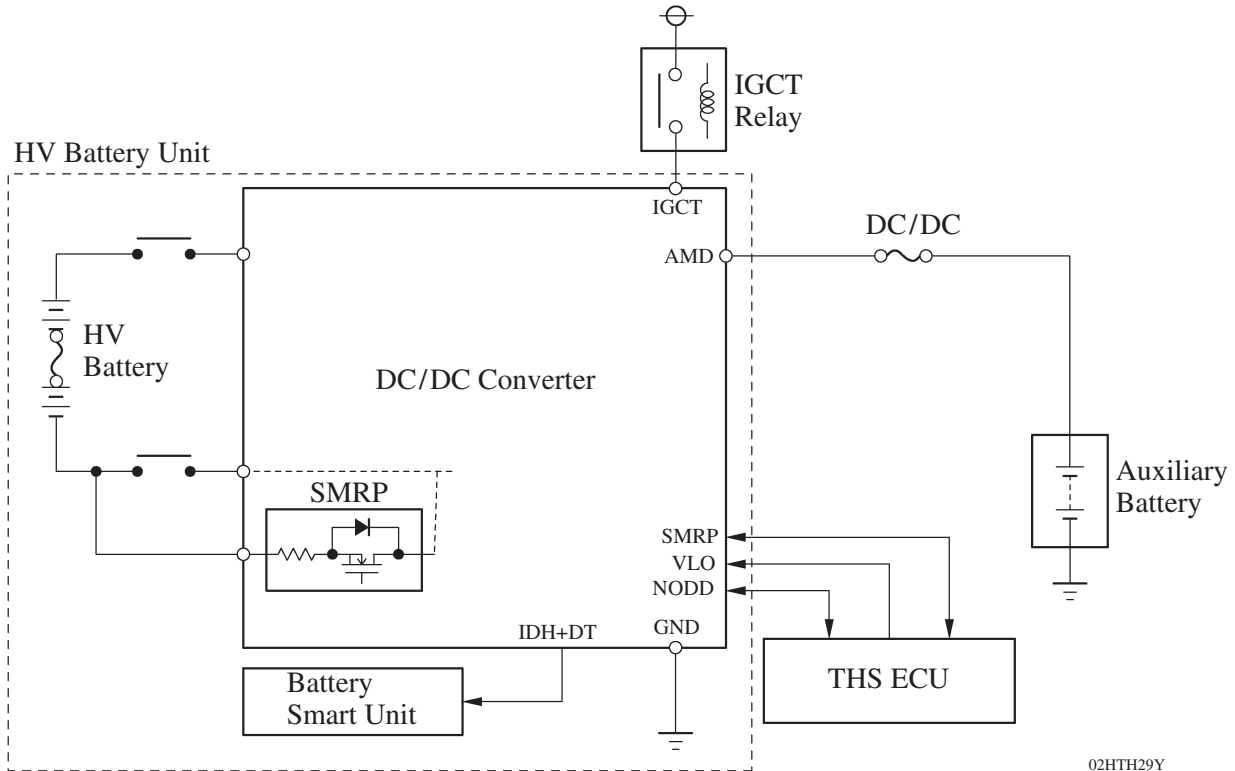

Junction Block

A junction block, in which an SMRG and SMRB are integrated, is used.

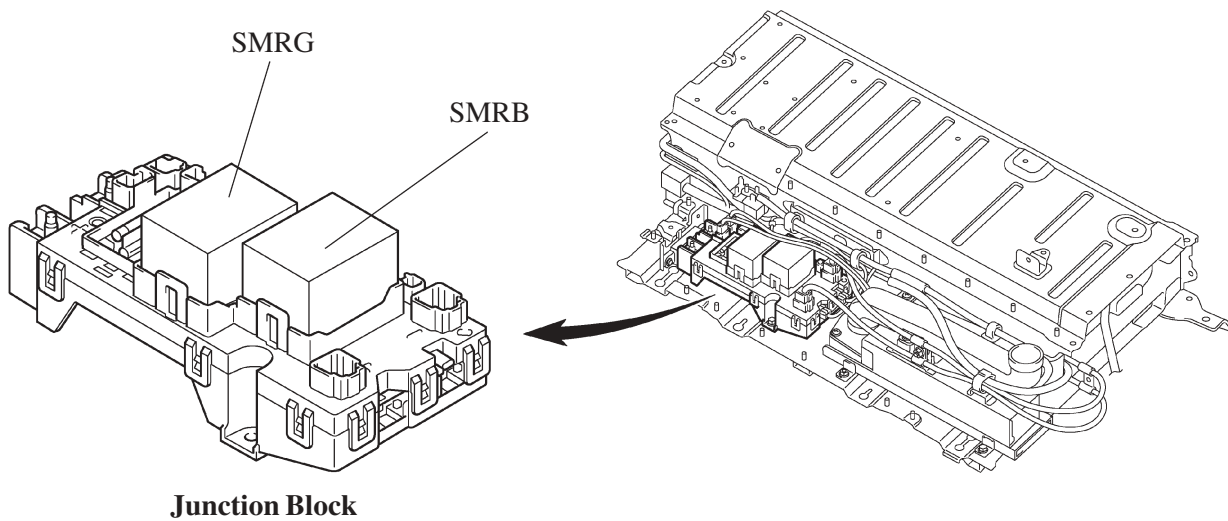

Service Plug

By removing the service plug before performing any inspection or service, the high-voltage circuit is shut off at the intermediate position of the HV battery, thus ensuring safety during service.

The service plug assembly contains a reed switch for interlock. Lifting the clip lock up turns OFF the lead switch, which shuts off the SMR. However, to ensure safety, make sure to turn OFF the ignition switch before removing the service plug.

The main fuse for the high-voltage circuit is provided inside of the service plug assembly.

For further details on how to handle the service plug and other safety cautions, refer to the 2007 Camry Hybrid Vehicle Repair Manual (Pub. No. RM02H0U).

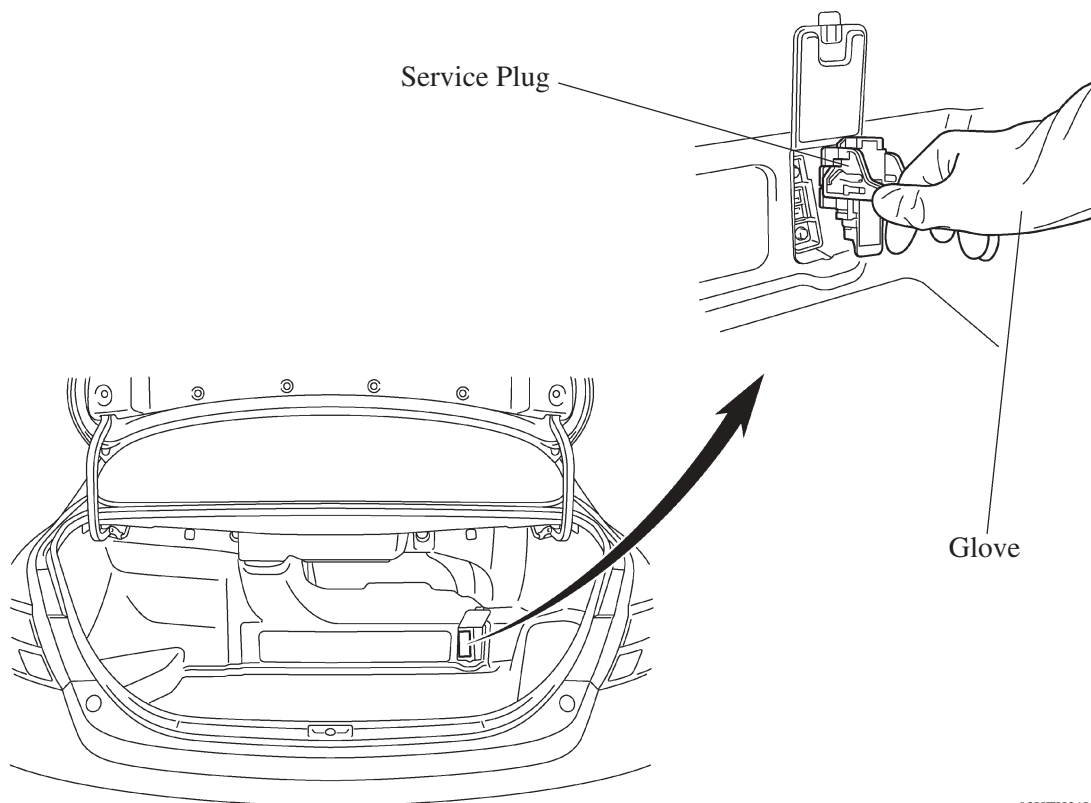

02HTH31Y

Service Tip

After the service, please do not start the system until the service plug is connected.
The battery smart unit may break down.

HV Battery and DC/DC Converter Cooling System

1) HV Battery Cooling System

- A dedicated cooling system is used to ensure that the HV battery performs properly, despite it generating significant heat during the repetitive charge and discharge cycles. This cooling system employs an air-cooling method, which uses the dedicated cooling fan to cool the HV battery with air from inside the cabin.
- The air from inside the cabin, which is introduced through the intake duct located on the rear package tray trim, flows downwards through the battery module, reducing the temperature of the battery module, and is emitted from the vehicle through the exhaust duct.
- The THS ECU controls the operation of the cooling fan for the HV battery. The THS ECU receives the signals from the battery temperature sensor, which is built into the HV battery, via the battery smart unit. Then, it controls the cooling fan in order to control the battery module temperature appropriately. For details, refer to THS ECU Control on [page TH-40](#).

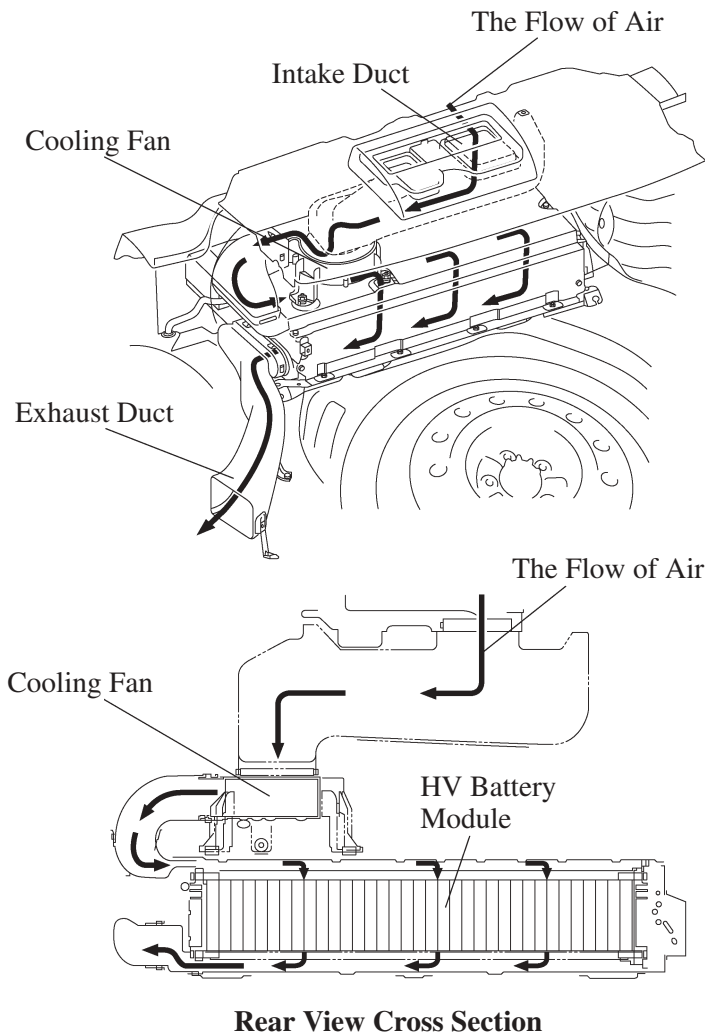

02HTH32TE

► HV Battery Cooling Fan Specifications ◀

Fan Type	Sirocco Fan
Motor Type	DC Motor (without Brush)

2) DC/DC Converter Cooling System

As with as the HV battery cooling system, the DC/DC converter cooling system uses a dedicated cooling fan to cool the converter. Air from inside the cabin is introduced through the intake duct located on the rear package tray trim. In addition, the converter itself is equipped with cooling fins. Thus, excellent air-cooling performance is achieved.

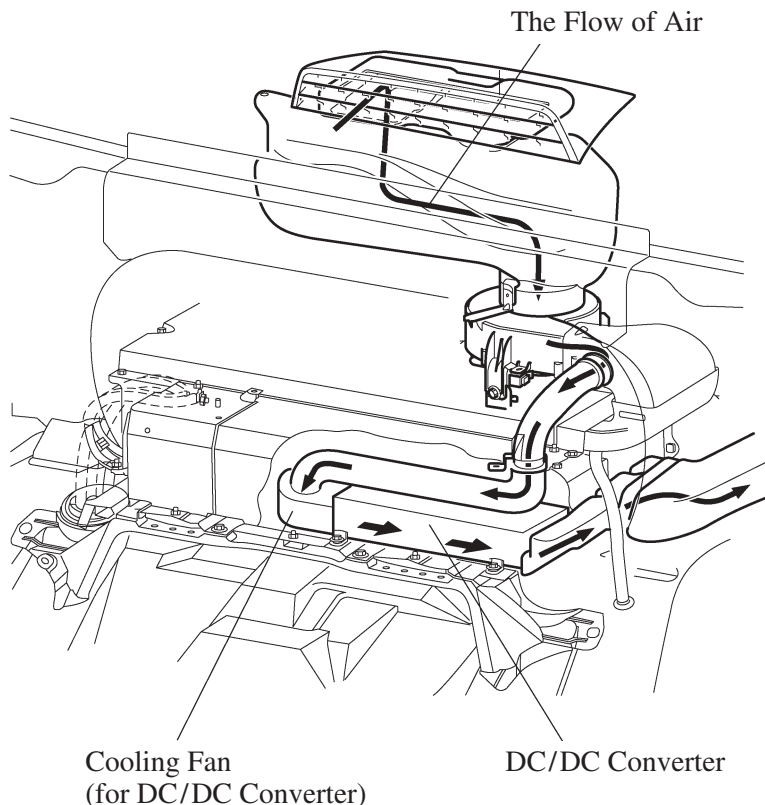

TH

02H1H21TE

► DC/DC Converter Cooling Fan Specifications ◀

Type	Sirocco Fan
Motor Type	DC Motor (without Brush)

5. Accelerator Pedal Position Sensor

The magnetic yoke that is mounted at the base of the accelerator pedal arm rotates around the Hall IC in accordance with the amount of effort that is applied to the accelerator pedal. The Hall IC converts the changes in the magnetic flux that occur at that time into electrical signals, and outputs them in the form of accelerator pedal effort to the THS ECU.

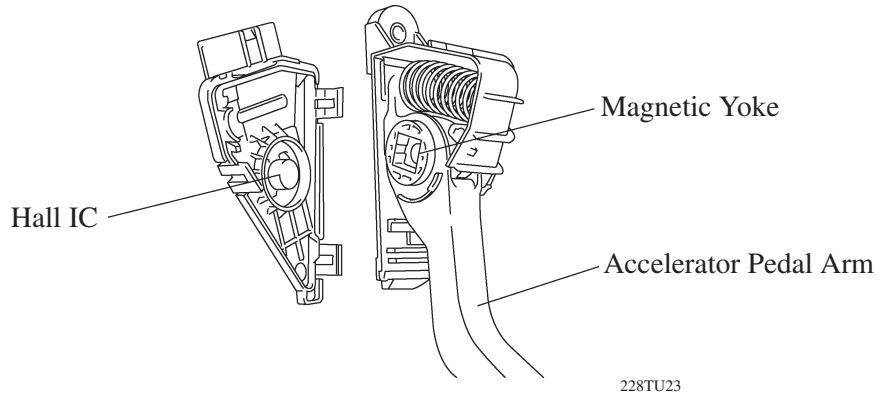

228TU23

Accelerator Pedal Position Sensor

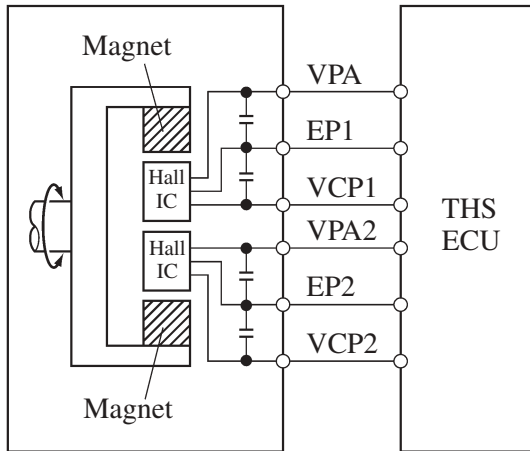

228TU24

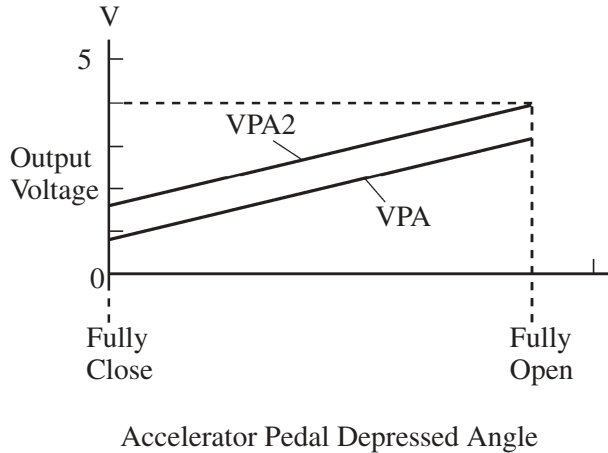

228TU25

Service Tip

The inspection method differs from the conventional accelerator pedal position sensor because this sensor uses a hall IC. For details, refer to the 2007 Camry Hybrid Vehicle Repair Manual (Pub. No. RM02H0U).

6. Power Cable

The power cable is a high-voltage, high-amperage cable that connects the HV battery module with the inverter, the inverter with MG1 and MG2, and the inverter with the electric inverter compressor. The power cable starts at the connector of the junction block of the HV battery, which is located behind the rear seat. It passes under the floor panel, along the side of the floor reinforcement, and connects to the inverter in the engine compartment. The power cable is shielded in order to reduce electromagnetic interference.

For identification purposes, the high-voltage wiring harness and connectors are color-coded orange to distinguish them from those of the ordinary low-voltage wiring.

